



## **TOWN OF FOXBOROUGH**

### **Inspections Department**

40 South Street

Foxborough, MA 02035

Telephone: (508) 543-1206 / Facsimile: (508) 543-6278

### **INSTRUCTIONS FOR STOVE PERMITS (heating appliances)**

The following information is needed to process your Stove Permit application:

1. The completed Stove Permit Application (installation only) with all information completely filled in.
2. Copies of the installing contractor's license and insurance.
3. One copy of the manufacturer's installation specifications must be included with the application and one copy must be kept on site for Inspector to use during stove inspection.
4. Stove Inspection Report – Items 1 & 2 should be filled out. Upon inspection, the Inspector will complete the balance of this form.

Stove may be installed after Stove Permit Application (Installation Only) has been signed. Upon installation, contact the Inspections Department to arrange for an inspection of the stove. The Stove Inspection Report must be approved prior to use of the stove.

- Attachments:
1. Stove Permit Application (Installation Only)
  2. Manufacturer's Instruction (Sample)
  3. Stove Inspection Report



# TOWN OF FOXBOROUGH

## Inspections Department

40 South Street

Foxborough, MA 02035

Telephone: (508) 543-1206 / Facsimile: (508) 543-6278

### STOVE PERMIT APPLICATION (Installation Only)

All stoves must have National Test Standard Tag on the appliance  
per Massachusetts State Building Code 3610.

Date: \_\_\_\_\_

Permit Fee: \$40.00 per unit

Applicant's Name: \_\_\_\_\_

Applicant's Address: \_\_\_\_\_ Telephone # \_\_\_\_\_

Property Owner's Name: \_\_\_\_\_

Property Owner's Address: \_\_\_\_\_ Telephone # \_\_\_\_\_

Stove Information (All stoves, per code, must be UL listed)

Type of Stove \_\_\_\_\_ (wood, coal, insert, etc.) Model: \_\_\_\_\_

Manufacturer: \_\_\_\_\_ National Listing: \_\_\_\_\_

Installer's Name/Company Name: \_\_\_\_\_

Address: \_\_\_\_\_ Telephone #: \_\_\_\_\_

License #: \_\_\_\_\_ Insurance Co. Name: \_\_\_\_\_

(please include copy, if not presently on file)

Chimney Type (type of lining): Masonry: \_\_\_\_\_ Metal: \_\_\_\_\_ Other: \_\_\_\_\_

Any other appliances on flue: \_\_\_\_\_ No: \_\_\_\_\_ Yes: \_\_\_\_\_

Name of appliance(s)

Stove Location: (Room, Floor/Level, etc.) \_\_\_\_\_

Estimated Value: \$ \_\_\_\_\_

Signature of Applicant: \_\_\_\_\_ Date: \_\_\_\_\_

#### Office Use Only

Above mentioned stove may be installed as described above.

\_\_\_\_\_  
Building Official Signature

\_\_\_\_\_  
Date

**A Stove Inspection Report from this Office is required after stove is installed and prior to use of stove.**



# TOWN OF FOXBOROUGH

## Inspections Department

40 South Street

Foxborough, MA 02035

Telephone: (508) 543-1206 / Facsimile: (508) 543-6278

### STOVE INSPECTION REPORT

Date of Inspection: \_\_\_\_\_

1. OWNER: \_\_\_\_\_ Lot No. \_\_\_\_\_ Map No. \_\_\_\_\_

ADDRESS: \_\_\_\_\_ Telephone # \_\_\_\_\_

#### STOVE INFORMATION:

2. Manufacturer: \_\_\_\_\_ Model: \_\_\_\_\_

Additional Information: \_\_\_\_\_

Location of Stove: (Room, Floor/Level, etc.) \_\_\_\_\_

Hearth: (Size, Type, Style, etc.) \_\_\_\_\_

Chimney type: \_\_\_\_\_

Any other appliances on flue: \_\_\_\_\_ No: \_\_\_\_\_ Yes: \_\_\_\_\_  
Name of appliance(s)

Smoke Detectors?: \_\_\_\_\_ No: \_\_\_\_\_ Yes: Type: \_\_\_\_\_

Stove inspected by: \_\_\_\_\_ Date: \_\_\_\_\_

Pass: \_\_\_\_\_ Fail: \_\_\_\_\_ Reinspection Required (Date): \_\_\_\_\_

Comments: \_\_\_\_\_



The Commonwealth of Massachusetts  
 Department of Industrial Accidents  
 1 Congress Street, Suite 100  
 Boston, MA 02114-2017  
 www.mass.gov/dia

Workers' Compensation Insurance Affidavit: Builders/Contractors/Electricians/Plumbers.  
 TO BE FILED WITH THE PERMITTING AUTHORITY.

**Applicant Information**

Please Print Legibly

Name (Business/Organization/Individual): \_\_\_\_\_

Address: \_\_\_\_\_

City/State/Zip: \_\_\_\_\_ Phone #: \_\_\_\_\_

<p>Are you an employer? Check the appropriate box:</p> <p>1. <input type="checkbox"/> I am an employer with _____ employees (full and/or part-time).*</p> <p>2. <input type="checkbox"/> I am a sole proprietor or partnership and have no employees working for me in any capacity. [No workers' comp. insurance required.]</p> <p>3. <input type="checkbox"/> I am a homeowner doing all work myself. [No workers' comp. insurance required.]†</p> <p>4. <input type="checkbox"/> I am a homeowner and will be hiring contractors to conduct all work on my property. I will ensure that all contractors either have workers' compensation insurance or are sole proprietors with no employees.</p> <p>5. <input type="checkbox"/> I am a general contractor and I have hired the sub-contractors listed on the attached sheet. These sub-contractors have employees and have workers' comp. insurance.‡</p> <p>6. <input type="checkbox"/> We are a corporation and its officers have exercised their right of exemption per MGL c. 152, §1(4), and we have no employees. [No workers' comp. insurance required.]</p>	<p>Type of project (required):</p> <p>7. <input type="checkbox"/> New construction</p> <p>8. <input type="checkbox"/> Remodeling</p> <p>9. <input type="checkbox"/> Demolition</p> <p>10. <input type="checkbox"/> Building addition</p> <p>11. <input type="checkbox"/> Electrical repairs or additions</p> <p>12. <input type="checkbox"/> Plumbing repairs or additions</p> <p>13. <input type="checkbox"/> Roof repairs</p> <p>14. <input type="checkbox"/> Other _____</p>
--	---

\*Any applicant that checks box #1 must also fill out the section below showing their workers' compensation policy information.  
 † Homeowners who submit this affidavit indicating they are doing all work and then hire outside contractors must submit a new affidavit indicating such.  
 ‡ Contractors that check this box must attached an additional sheet showing the name of the sub-contractors and state whether or not those entities have employees. If the sub-contractors have employees, they must provide their workers' comp. policy number.

**I am an employer that is providing workers' compensation insurance for my employees. Below is the policy and job site information.**

Insurance Company Name: \_\_\_\_\_

Policy # or Self-ins. Lic. #: \_\_\_\_\_ Expiration Date: \_\_\_\_\_

Job Site Address: \_\_\_\_\_ City/State/Zip: \_\_\_\_\_

**Attach a copy of the workers' compensation policy declaration page (showing the policy number and expiration date).**

Failure to secure coverage as required under MGL c. 152, §25A is a criminal violation punishable by a fine up to \$1,500.00 and/or one-year imprisonment, as well as civil penalties in the form of a STOP WORK ORDER and a fine of up to \$250.00 a day against the violator. A copy of this statement may be forwarded to the Office of Investigations of the DIA for insurance coverage verification.

**I do hereby certify under the pains and penalties of perjury that the information provided above is true and correct.**

Signature: \_\_\_\_\_ Date: \_\_\_\_\_

Phone #: \_\_\_\_\_

**Official use only. Do not write in this area, to be completed by city or town official.**

City or Town: \_\_\_\_\_ Permit/License # \_\_\_\_\_

Issuing Authority (circle one):  
 1. Board of Health 2. Building Department 3. City/Town Clerk 4. Electrical Inspector 5. Plumbing Inspector  
 6. Other \_\_\_\_\_

Contact Person: \_\_\_\_\_ Phone #: \_\_\_\_\_

# Information and Instructions

Massachusetts General Laws chapter 152 requires all employers to provide workers' compensation for their employees. Pursuant to this statute, an *employee* is defined as "...every person in the service of another under any contract of hire, express or implied, oral or written."

An *employer* is defined as "an individual, partnership, association, corporation or other legal entity, or any two or more of the foregoing engaged in a joint enterprise, and including the legal representatives of a deceased employer, or the receiver or trustee of an individual, partnership, association or other legal entity, employing employees. However the owner of a dwelling house having not more than three apartments and who resides therein, or the occupant of the dwelling house of another who employs persons to do maintenance, construction or repair work on such dwelling house or on the grounds or building appurtenant thereto shall not because of such employment be deemed to be an employer."

MGL chapter 152, §25C(6) also states that "every state or local licensing agency shall withhold the issuance or renewal of a license or permit to operate a business or to construct buildings in the commonwealth for any applicant who has not produced acceptable evidence of compliance with the insurance coverage required." Additionally, MGL chapter 152, §25C(7) states "Neither the commonwealth nor any of its political subdivisions shall enter into any contract for the performance of public work until acceptable evidence of compliance with the insurance requirements of this chapter have been presented to the contracting authority."

---

## Applicants

Please fill out the workers' compensation affidavit completely, by checking the boxes that apply to your situation and, if necessary, supply sub-contractor(s) name(s), address(es) and phone number(s) along with their certificate(s) of insurance. Limited Liability Companies (LLC) or Limited Liability Partnerships (LLP) with no employees other than the members or partners, are not required to carry workers' compensation insurance. If an LLC or LLP does have employees, a policy is required. Be advised that this affidavit may be submitted to the Department of Industrial Accidents for confirmation of insurance coverage. **Also be sure to sign and date the affidavit.** The affidavit should be returned to the city or town that the application for the permit or license is being requested, not the Department of Industrial Accidents. Should you have any questions regarding the law or if you are required to obtain a workers' compensation policy, please call the Department at the number listed below. Self-insured companies should enter their self-insurance license number on the appropriate line.

---

## City or Town Officials

Please be sure that the affidavit is complete and printed legibly. The Department has provided a space at the bottom of the affidavit for you to fill out in the event the Office of Investigations has to contact you regarding the applicant. Please be sure to fill in the permit/license number which will be used as a reference number. In addition, an applicant that must submit multiple permit/license applications in any given year, need only submit one affidavit indicating current policy information (if necessary) and under "Job Site Address" the applicant should write "all locations in \_\_\_\_\_ (city or town)." A copy of the affidavit that has been officially stamped or marked by the city or town may be provided to the applicant as proof that a valid affidavit is on file for future permits or licenses. A new affidavit must be filled out each year. Where a home owner or citizen is obtaining a license or permit not related to any business or commercial venture (i.e. a dog license or permit to burn leaves etc.) said person is NOT required to complete this affidavit.

---

The Department's address, telephone and fax number:

The Commonwealth of Massachusetts  
Department of Industrial Accidents  
1 Congress Street, Suite 100  
Boston, MA 02114-2017

Tel. # 617-727-4900 ext. 7406 or 1-877-MASSAFE  
Fax # 617-727-7749  
www.mass.gov/dia

## Tentative Interim Amendment 211-84-1 to the Standard for Chimneys, Fireplaces, Vents and Solid Fuel Burning Appliances NFPA 211-1984

Pursuant to Section 15 of the NFPA Regulations Governing Committee Projects, the National Fire Protection Association has issued the following Tentative Interim Amendment to NFPA 211, *Standard for Chimneys, Fireplaces, Vents and Solid Fuel Burning Appliances*, 1984 edition. The TIA was processed by the Committee on Chimneys, Fireplaces and Venting Systems for Heat Producing Appliances and was issued by the Standards Council on July 12, 1985.

A Tentative Interim Amendment is tentative because it has not been processed through the entire standards-making procedures. It is interim because it is effective only between editions of the standard. A TIA automatically becomes a Proposal of the proponent for the next edition of the standard; as such, it then is subject to all the procedures of the standards-making process.

1. Revise 5-7.4 and 5-7.5 to read as follows:

5-7.4 Connectors for residential-type appliances [Table 1-2 (a), Column I] may pass through walls or partitions constructed of combustible material to a masonry chimney or another room if the connector is either listed for wall pass-through or is routed through a device listed for wall pass-through and is installed in accordance with the conditions of the listing.

5-7.5 Connectors for residential-type appliances may pass through walls or partitions constructed of combustible material to a masonry chimney or another room if the connector system selected or fabricated is installed in accordance with the conditions and clearances in Table 5-7.

Table 5-7  
Chimney Connector Systems and Clearances from Room Wall Combustibles  
for Residential Heating Appliances

System

Clearance  
in/mm

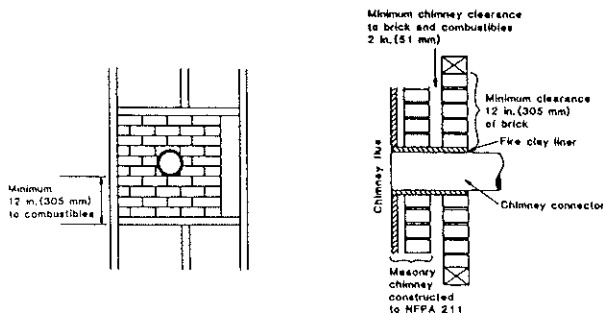

A. Minimum 3.5-in. (90-mm) thick brick masonry wall framed into combustible wall with a minimum of 12 in. (305 mm) brick separation from clay liner to combustibles. Fire clay liner (ASTM C315 or equivalent), minimum 3/4-in. (16-mm) wall thickness, shall run from outer surface of brick wall to, but not beyond, the inner surface of chimney flue liner and shall be firmly cemented in place.

12/305

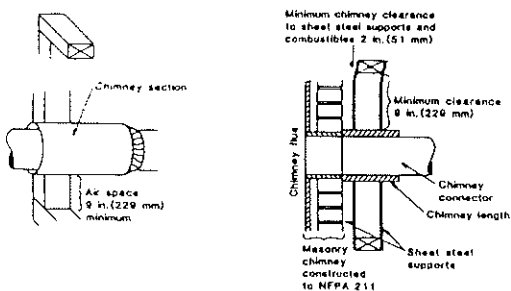

B. 6-in. (152-mm) inside diameter solid insulated listed factory-built chimney length having 1 in. (25 mm) or more of insulation with a minimum 9 in. (229 mm) air space between the outer wall of chimney section and combustibles. Minimum length of chimney section shall be 12 in. (305 mm). Opening shall be covered and chimney section supported on both sides with sheet steel supports, minimum 24 gage (0.024 in./0.61 mm) in thickness. Supports shall be securely fastened to wall surface on all sides but shall be sized to fit and hold chimney section without fasteners.

9/229

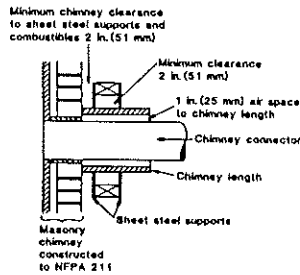
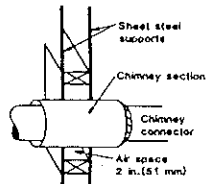
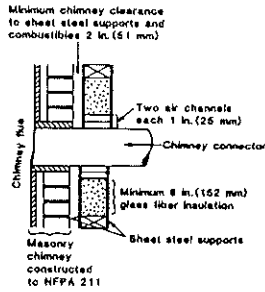
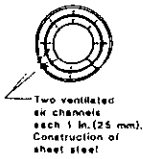

C. 6-in. (152-mm) inside diameter sheet steel chimney connector, minimum 24 gage (0.024 in./0.61 mm) in thickness, with a ventilated thimble, minimum 24 gage (0.024 in./0.61 mm) in thickness, having two ventilated 1-in. (25-mm) air channels, separated from combustibles by a minimum of 6 in. (152 mm) of glass fiber insulation. Opening shall be covered and thimble supported with a sheet steel support, minimum 24 gage (0.024 in./0.61 mm) in thickness. Support shall be securely fastened to wall surface on all sides but shall be sized to fit and hold thimble without fasteners.

6-152

D. 8-in. (203-mm) inside diameter solid insulated listed factory-built chimney length having 1 in. (25 mm) or more of insulation, serving as a pass-through for a 6-in. (152-mm) inside diameter single wall sheet steel chimney connector, minimum 24 gage (0.024 in./0.61 mm) in thickness, with a minimum 2 in. (51 mm) air space between the outer wall of chimney section and combustibles. Minimum length of chimney section shall be 12 in. (305 mm). Chimney section concentric with and spaced 1 in. (25 mm) away from connector by means of sheet steel support plates on both ends of chimney section. Opening shall be covered and chimney section supported on both sides with sheet steel supports, minimum 24 gage (0.024 in./0.61 mm) in thickness. Supports shall be securely fastened to wall surface on all sides but shall be sized to fit and hold chimney section and chimney connector without fasteners.

2-51

Notes:

1. Insulation material used as part of a wall pass-through system shall be of noncombustible material and shall have a thermal conductivity of 1.0 BTU·in./ft<sup>2</sup>·hr·°F (4.88 kg·cal/hr·m<sup>2</sup>·°C) or less.
2. All clearances and thicknesses are minimums; larger clearances and thicknesses are acceptable.
3. Any material used to close up an opening for the connector shall be of noncombustible material.
4. Any unexposed metal that is used as part of a wall pass-through system and is exposed to flue gases shall be constructed of stainless steel or other approved material that will resist corrosion, softening, or cracking from flue gases at temperatures up to 1800°F (982°C).

Building permit is required for the installation of any solid fuel burning appliance. The building permit and installation inspection are limited to the stove installation and not to the stove construction.

**Stove**

A. New \_\_\_\_\_ Used \_\_\_\_\_  
 B. Type/radiant \_\_\_\_\_ Circulating \_\_\_\_\_  
 C. Manufacturer \_\_\_\_\_ Lab. No. \_\_\_\_\_  
 Name/Model No. \_\_\_\_\_ Collar size \_\_\_\_\_  
 Dimensions/Height \_\_\_\_\_ Length \_\_\_\_\_ Width \_\_\_\_\_

**Chimney**

A. New \_\_\_\_\_ Existing \_\_\_\_\_  
 B. Size (flue area) \_\_\_\_\_  
 C. Other appliances attached to flue (Number and flue size) \_\_\_\_\_  
 D. Prefab (Manufacturer—name and type) \_\_\_\_\_  
 E. Masonry/Lined \_\_\_\_\_ Flue liner \_\_\_\_\_  
 Unlined \_\_\_\_\_ (type & manufacturer) \_\_\_\_\_  
 F. Height (refer to diagrams) \_\_\_\_\_ cap \_\_\_\_\_

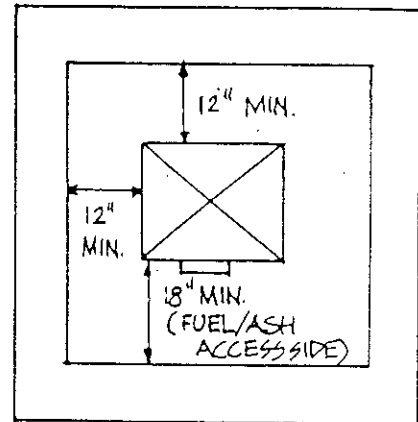
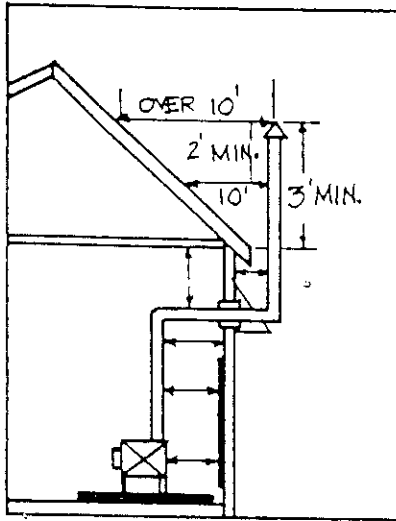
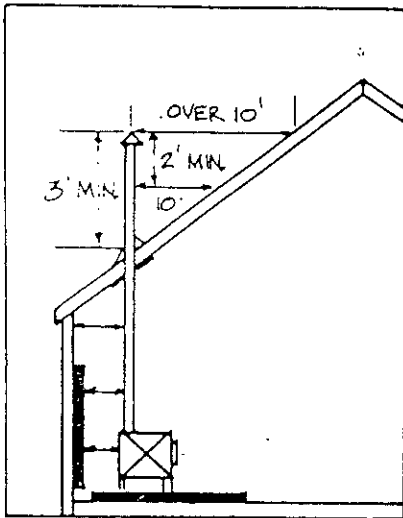

HEARTH

CHIMNEY HEIGHT

**Hearth (non-combustible)**

A. Materials \_\_\_\_\_  
 B. Sub-floor construction \_\_\_\_\_  
 C. Minimum dimensions (refer to diagram) \_\_\_\_\_

*DAMPERS CLOSE*

**Clearances and Wall Protection (see stove installation clearances chart)**

A. Type of wall protection provided \_\_\_\_\_  
 B. Clearances (refer to diagrams) \_\_\_\_\_

*12 1/2" TO MANTEL  
24"*

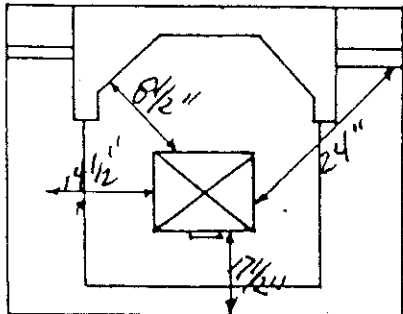

FIREPLACE

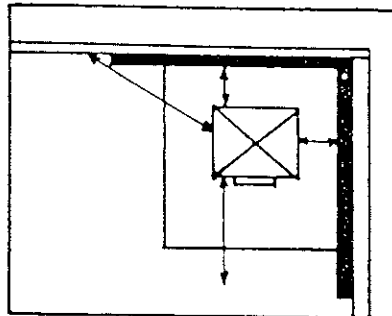

CORNER

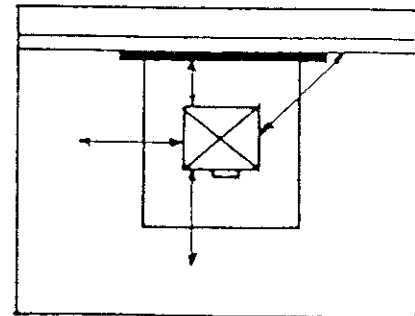

WALL/CENTER



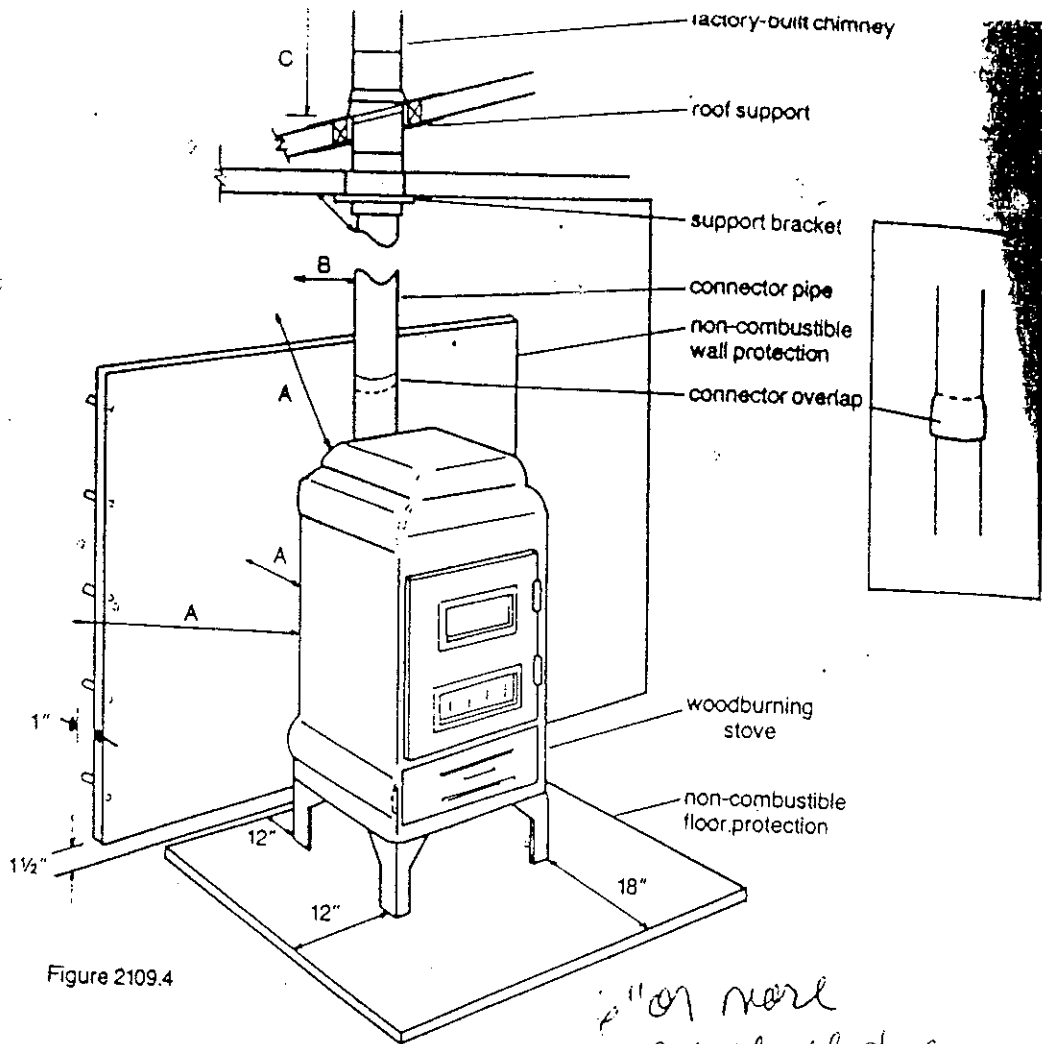

Figure 2109.4

*2" or more  
2" of solidness*

Figure 2109.4  
STOVE INSTALLATION CLEARANCES

Stove Components	Combustible Material	½" Asbestos Millboard Spaced Out 1" 2.	Concrete/Masonry Foundation Wall	Spaced Out 1" 4" Brick Veneer
Radiant Stove 1. —Front	36"	—	—	—
Circulating Stove —Front	24"	—	—	—
A. Radiant Stove 3. —Side/Back/Top	36"	18"	6"	18"
A. Circulating Stove —Side/Back/Top	12"	6"	6"	6"
B. Single Wall Connector Pipe	18"	12"	6"	8"
B. Insulated Connector Pipe	2"	2"	2"	2"
C. Chimney Height (Metal or Masonry)	Three (3) feet above adjacent roof and two (2) feet above any roof ridge within 10 feet			
D. Damper	If a damper is not included in the stove construction, it must be installed in the connector pipe.			

1. Front: Fuel or ash access side.
  2. Non-combustible spacers required.
  3. Clearances on each side of a radiant stove with a heat shield shall be measured as if a circulating type.
- Note: Clearances shall be measured perpendicular to stove body.  
Laboratory verified test clearances permitted.